

L:
 CBL-HFD3SAB6MBS-6m 6000mm±30mm
 CBL-HFD3SAB6MBS-7m 7000mm±30mm
 CBL-HFD3SAB6MBS-8m 8000mm±30mm
 CBL-HFD3SAB6MBS-9m 9000mm±30mm
 CBL-HFD3SAB6MBS-10m 10000mm±30mm

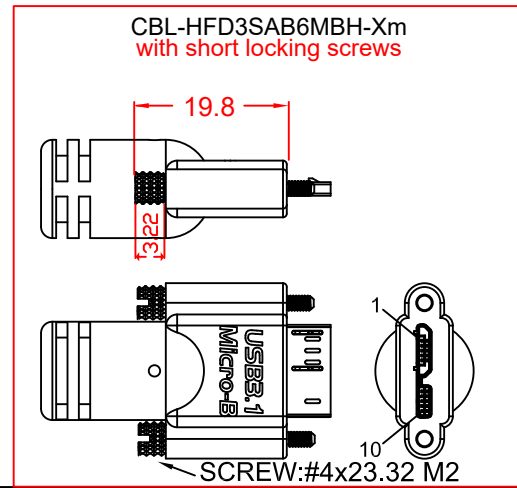
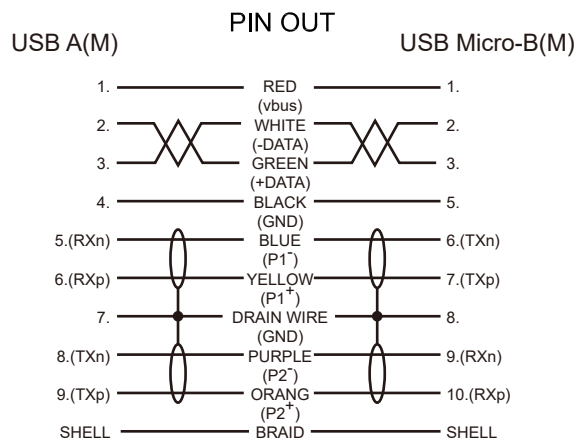

No	MATERIALS LIST:
1.	CABLE: 3 x (2 x 24 AWG)ST + 2 x 22 AWG O.D.:.8.8mm COLOR:RED LILAC
2.	CONNECTOR:USB 3.0 A/M, 9P, BLUE INSULATOR SOLDER TYPE, NICKEL PLATED SHELL
3.	CONNECTOR:USB 3.0 MicroB/M, 10P, BLACK INSULATOR SOLDER TYPE, NICKEL PLATED SHELL
4.	PVC MOLDED HOUSING, BLACK COLOR
5.	SCREW:#4x33 M2

Jargy part no.	Client part no.	Approved	SCALE	UNIT
CBL-HFD3SAB6MBS-xm				mm
Drawing Name		Drawn	Date	REV.
USB 3.0 A to MicroB Cable M/M				1.0

Mobile Computing JARGY

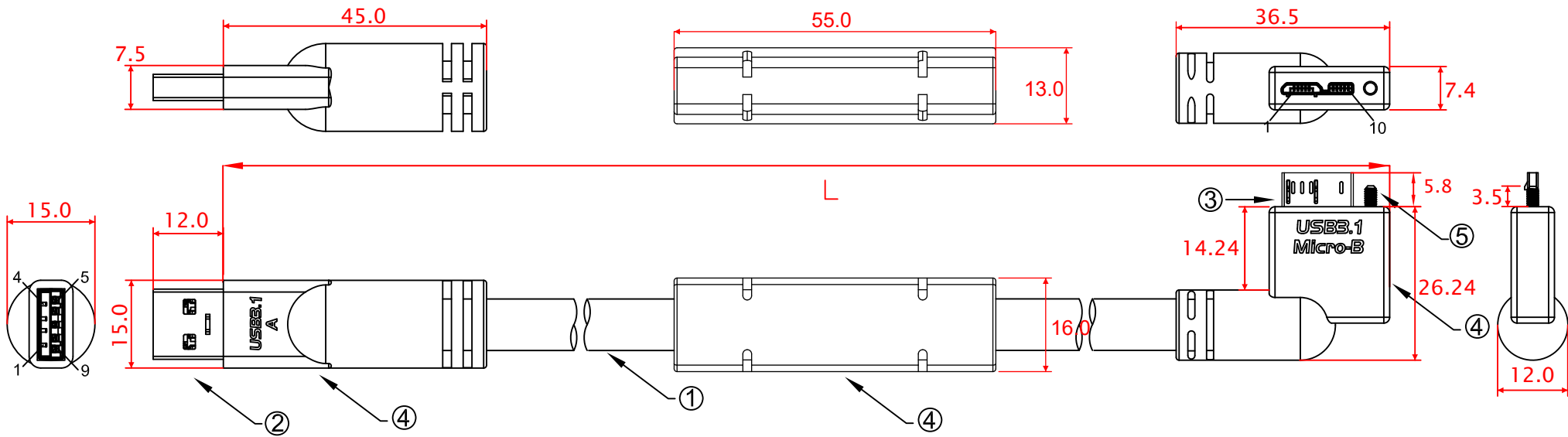

- L:
- CBL-HFD3SAB6MBH-6mLA 6000mm±30mm
 - CBL-HFD3SAB6MBH-7mLA 7000mm±30mm
 - CBL-HFD3SAB6MBH-8mLA 8000mm±30mm
 - CBL-HFD3SAB6MBH-9mLA 9000mm±30mm
 - CBL-HFD3SAB6MBH-10mLA 10000mm±30mm

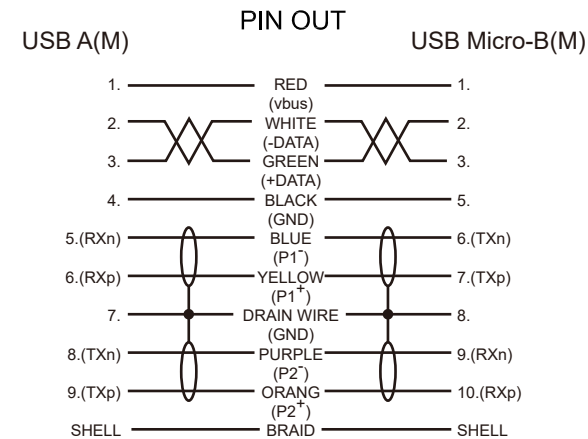

No	MATERIALS LIST:
1.	CABLE: 3 x (2 x 24 AWG)ST + 2 x 22 AWG O.D.:8.8mm COLOR:RED LILAC
2.	CONNECTOR:USB 3.0 A/M, 9P, BLUE INSULATOR SOLDER TYPE, NICKEL PLATED SHELL
3.	CONNECTOR:USB 3.0 MicroB/M, 10P, BLACK INSULATOR SOLDER TYPE, NICKEL PLATED SHELL
4.	PVC MOLDED HOUSING, BLACK COLOR
5.	SCREW:#4x23.32 M2

Jargy part no.	Client part no.	Approved	SCALE	UNIT
CBL-HFD3SAB6MBH-xmLA				mm
Drawing Name		Drawn	Date	REV.
USB 3.0 A to MicroB Cable M/M				1.0

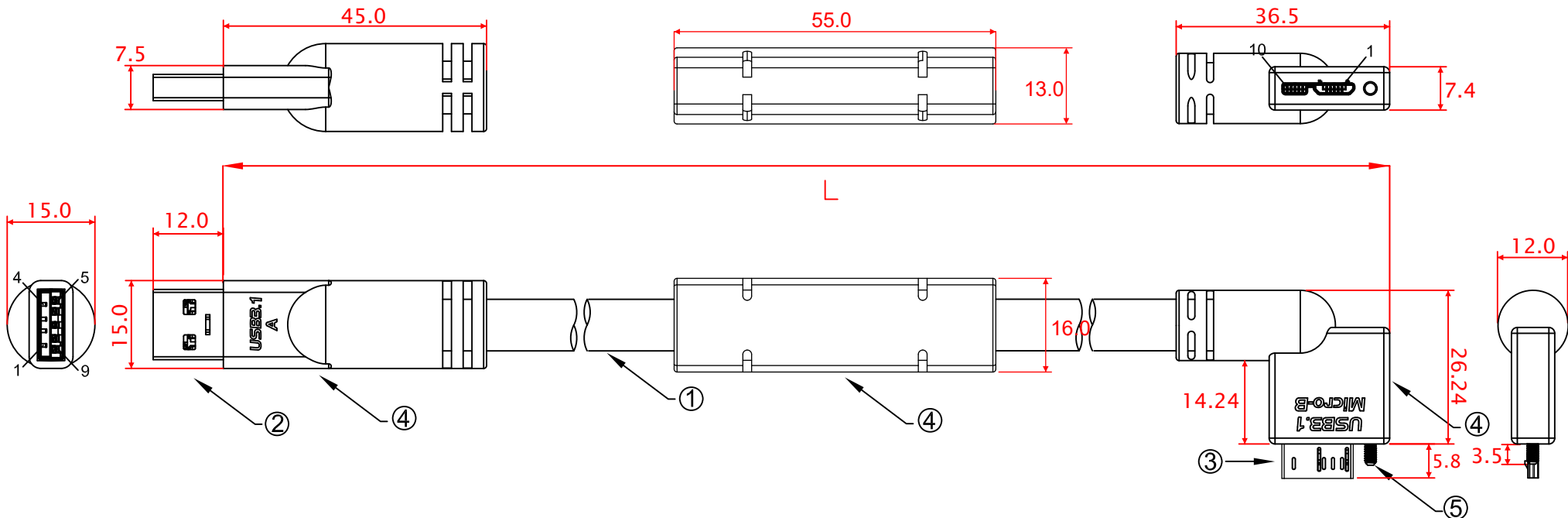

- L:
- CBL-HFD3SAB6MBH-6mRA 6000mm±30mm
 - CBL-HFD3SAB6MBH-7mRA 7000mm±30mm
 - CBL-HFD3SAB6MBH-8mRA 8000mm±30mm
 - CBL-HFD3SAB6MBH-9mRA 9000mm±30mm
 - CBL-HFD3SAB6MBH-10mRA 10000mm±30mm

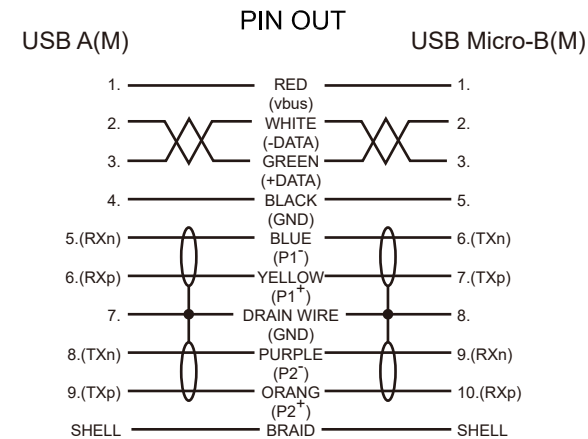

No	MATERIALS LIST:
1.	CABLE: 3 x (2 x 24 AWG)ST + 2 x 22 AWG O.D.:8.8mm COLOR:RED LILAC
2.	CONNECTOR:USB 3.0 A/M, 9P, BLUE INSULATOR SOLDER TYPE, NICKEL PLATED SHELL
3.	CONNECTOR:USB 3.0 MicroB/M, 10P, BLACK INSULATOR SOLDER TYPE, NICKEL PLATED SHELL
4.	PVC MOLDED HOUSING, BLACK COLOR
5.	SCREW:#4x23.32 M2

Jargy part no.	Client part no.	Approved	SCALE	UNIT
CBL-HFD3SAB6MBH-xmRA				mm
Drawing Name		Drawn	Date	REV.
USB 3.0 A to MicroB Cable M/M				1.0

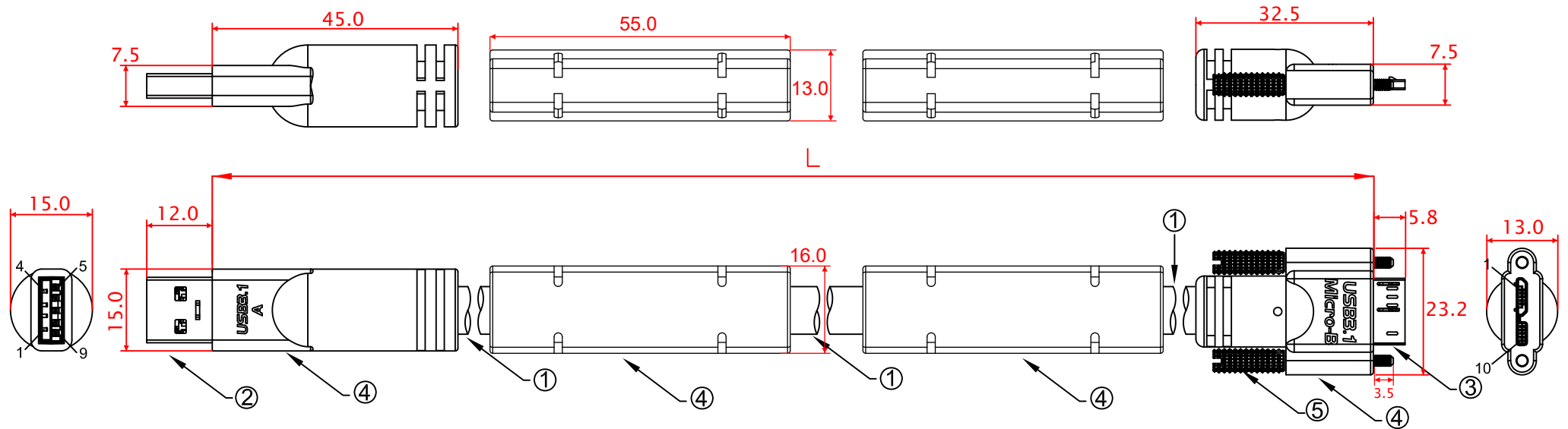

L:

CBL-HFD3SAB6MBS-11m	11000±50mm
CBL-HFD3SAB6MBS-12m	12000±50mm
CBL-HFD3SAB6MBS-13m	13000±50mm
CBL-HFD3SAB6MBS-14m	14000±50mm

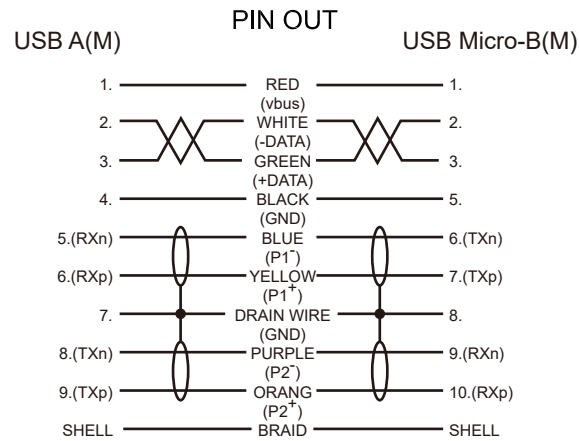

CBL-HFD3SAB6MBH-Xm
with short locking screws

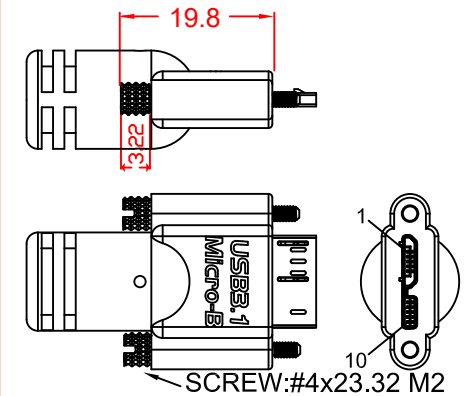

No	MATERIALS LIST:
1.	CABLE: 3 x (2 x 24 AWG)ST + 2 x 22 AWG O.D.:8.8mm COLOR:RED LILAC
2.	CONNECTOR:USB 3.0 A/M, 9P, BLUE INSULATOR SOLDER TYPE, NICKEL PLATED SHELL
3.	CONNECTOR:USB 3.0 MicroB/M, 10P, BLACK INSULATOR SOLDER TYPE, NICKEL PLATED SHELL
4.	PVC MOLDED HOUSING, BLACK COLOR
5.	SCREW:#4x33 M2
6.	

Jargy part no.	Client part no.	Approved	SCALE	UNIT
CBL-HFD3SAB6MBS-xm				mm
Drawing Name		Drawn	Date	REV.
USB 3.0 A to MicroB Cable M/M				1.0

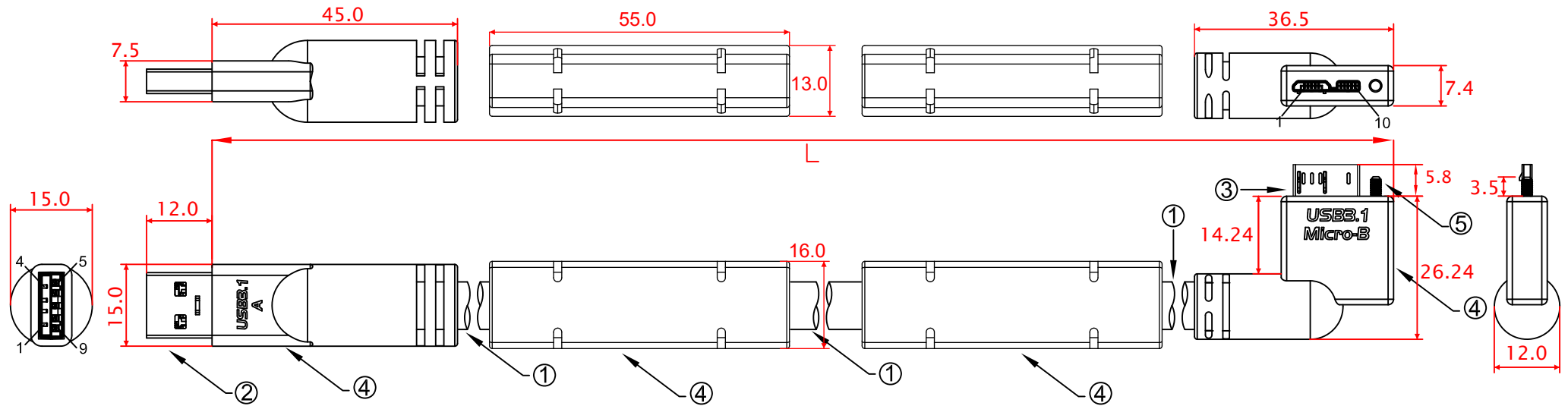

L:
 CBL-HFD3SAB6MBH-11mLA 11000±50mm
 CBL-HFD3SAB6MBH-12mLA 12000±50mm
 CBL-HFD3SAB6MBH-13mLA 13000±50mm
 CBL-HFD3SAB6MBH-14mLA 14000±50mm

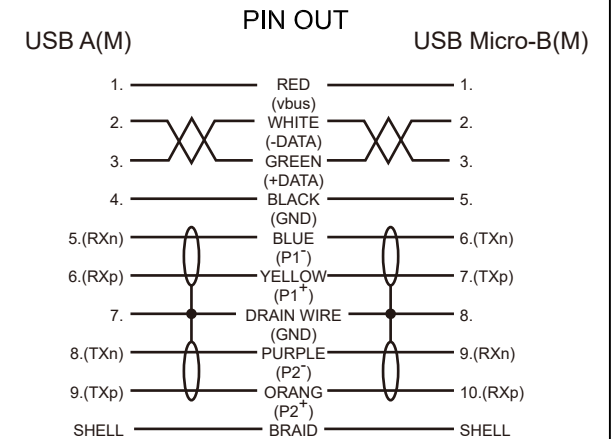

No	MATERIALS LIST:
1.	CABLE: 3 x (2 x 24 AWG)ST + 2 x 22 AWG O.D.:8.8mm COLOR:RED LILAC
2.	CONNECTOR:USB 3.0 A/M, 9P, BLUE INSULATOR SOLDER TYPE, NICKEL PLATED SHELL
3.	CONNECTOR:USB 3.0 MicroB/M, 10P, BLACK INSULATOR SOLDER TYPE, NICKEL PLATED SHELL
4.	PVC MOLDED HOUSING, BLACK COLOR
5.	SCREW:#4x23.32 M2
6.	

Jargy part no.	Client part no.	Approved	SCALE	UNIT
CBL-HFD3SAB6MBH-xmLA				mm
Drawing Name		Drawn	Date	REV.
USB 3.0 A to MicroB Cable M/M				1.0

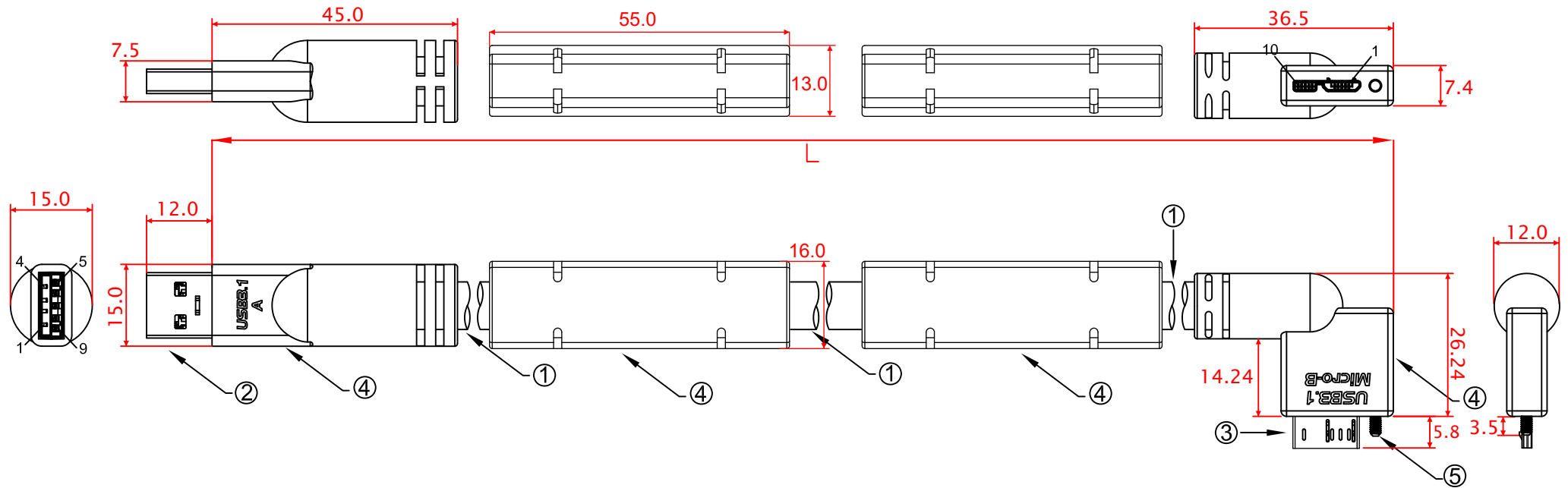

- L:
- CBL-HFD3SAB6MBH-11mRA 11000±50mm
 - CBL-HFD3SAB6MBH-12mRA 12000±50mm
 - CBL-HFD3SAB6MBH-13mRA 13000±50mm
 - CBL-HFD3SAB6MBH-14mRA 14000±50mm

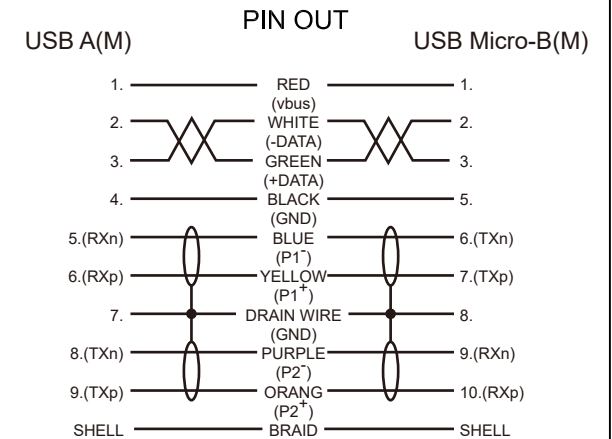

No	MATERIALS LIST:
1.	CABLE: 3 x (2 x 24 AWG)ST + 2 x 22 AWG O.D.:8.8mm COLOR:RED LILAC
2.	CONNECTOR:USB 3.0 A/M, 9P, BLUE INSULATOR SOLDER TYPE, NICKEL PLATED SHELL
3.	CONNECTOR:USB 3.0 MicroB/M, 10P, BLACK INSULATOR SOLDER TYPE, NICKEL PLATED SHELL
4.	PVC MOLDED HOUSING, BLACK COLOR
5.	SCREW:#4x23.32 M2
6.	

Jargy part no.	Client part no.	Approved	SCALE	UNIT
CBL-HFD3SAB6MBH-xmRA				mm
Drawing Name		Drawn	Date	REV.
USB 3.0 A to MicroB Cable M/M				1.0

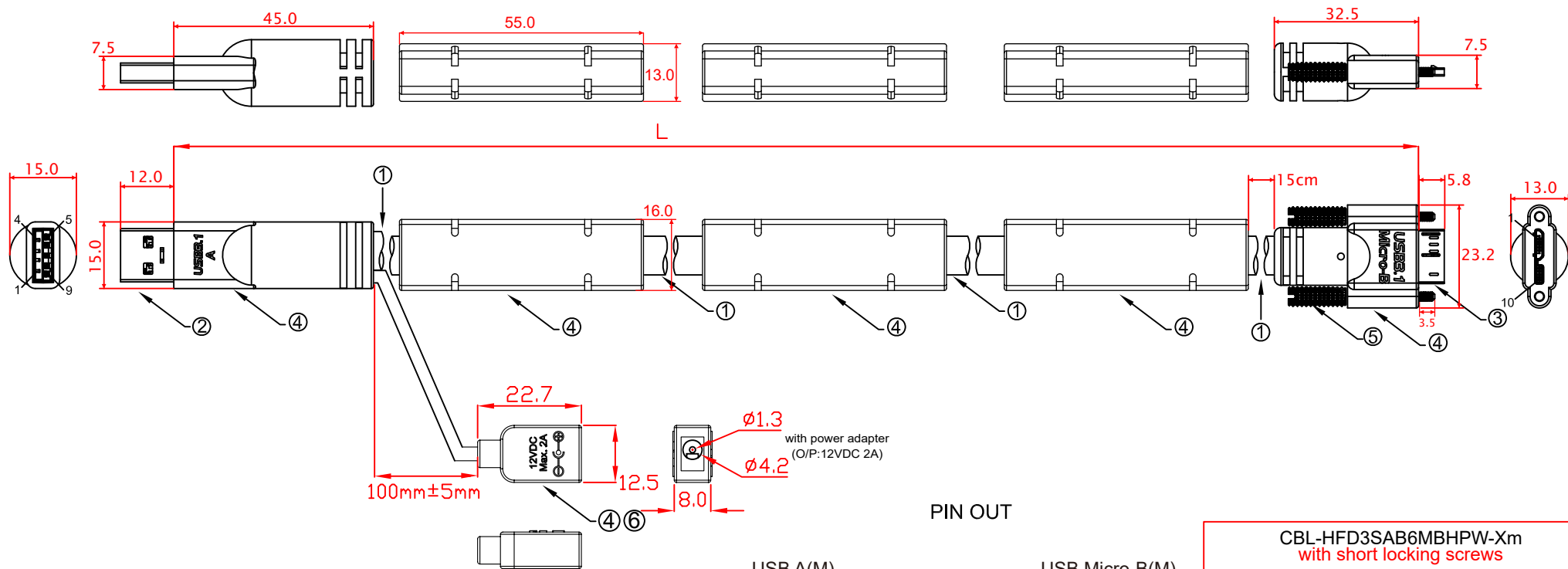

L:
CBL-HFD3SAB6MBSPW-15m 15000±50mm

PIN OUT

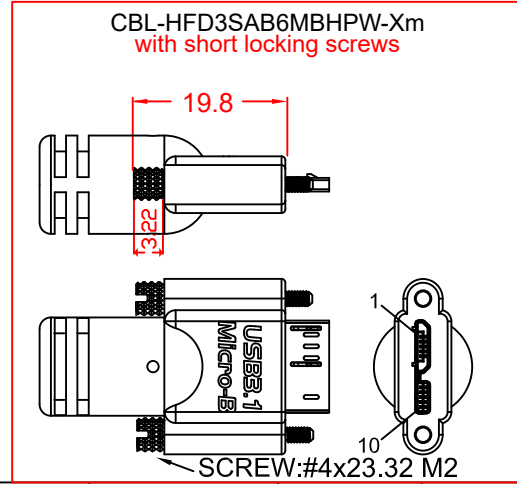
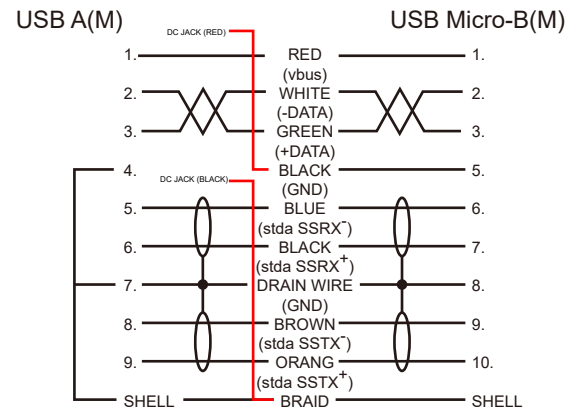

No	MATERIALS LIST:
1.	CABLE: 3 x (2 x 24 AWG)ST + 2 x 22 AWG O.D.:8.8mm COLOR:RED LILAC
2.	CONNECTOR:USB 3.0 A/M, 9P, BLUE INSULATOR SOLDER TYPE, NICKEL PLATED SHELL
3.	CONNECTOR:USB 3.0 MicroB/M, 10P, BLACK INSULATOR SOLDER TYPE, NICKEL PLATED SHELL
4.	PVC MOLDED HOUSING, BLACK COLOR
5.	SCREW:#4x33 M2
6.	DC JACK 1.3mm 30V 0.3V

Jargy part no.	Client part no.	Approved	SCALE	UNIT
CBL-HFD3SAB6MBSPW-xm				mm
Drawing Name		Drawn	Date	REV.
USB 3.0 A to MicroB Cable M/M				1.0

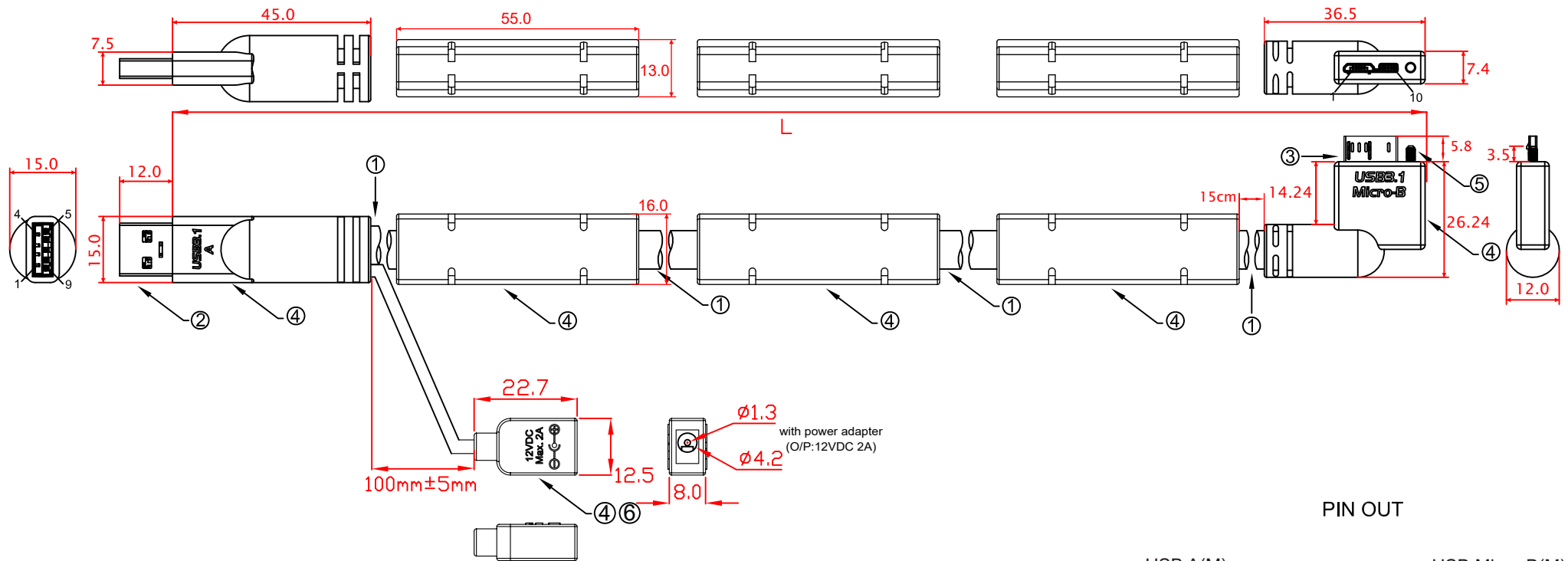

L:
CBL-HFD3SAB6MBHPW-15mLA 15000±50mm

No	MATERIALS LIST:
1.	CABLE: 3 x (2 x 24 AWG)ST + 2 x 22 AWG O.D.:8.8mm COLOR:RED LILAC
2.	CONNECTOR:USB 3.0 A/M, 9P, BLUE INSULATOR SOLDER TYPE, NICKEL PLATED SHELL
3.	CONNECTOR:USB 3.0 MicroB/M, 10P, BLACK INSULATOR SOLDER TYPE, NICKEL PLATED SHELL
4.	PVC MOLDED HOUSING, BLACK COLOR
5.	SCREW:#4x23.32 M2
6.	DC JACK 1.3mm 30V 0.3V

PIN OUT

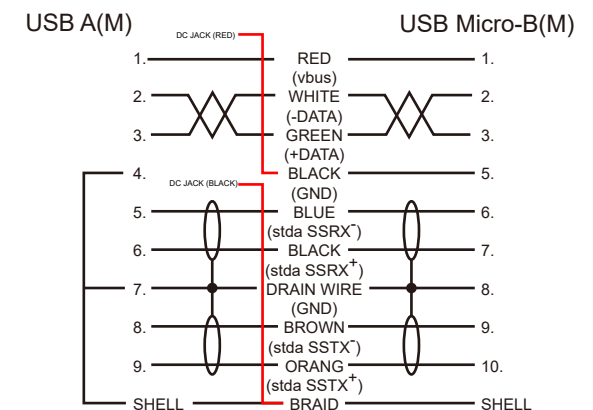

Jargy part no.	Client part no.	Approved	SCALE	UNIT
CBL-HFD3SAB6MBHPW-xmLA				mm
Drawing Name		Drawn	Date	REV.
USB 3.0 A to MicroB Cable M/M				1.0

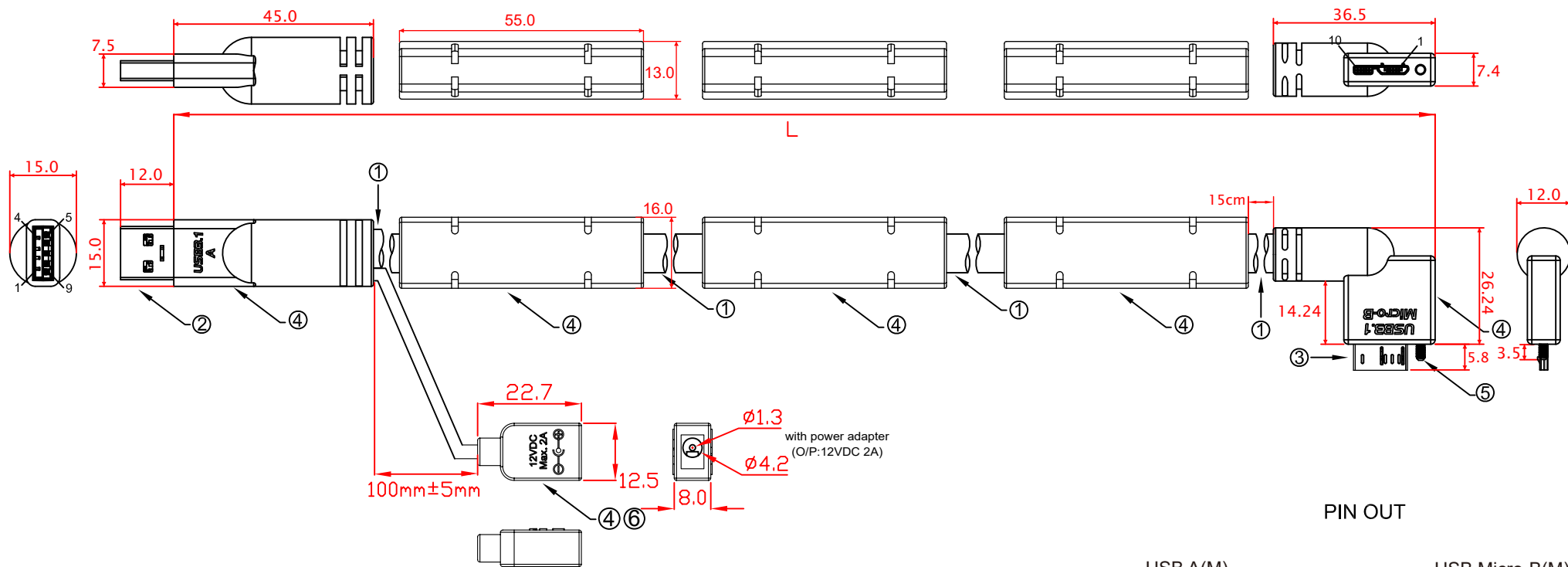

L:
CBL-HFD3SAB6MBHPW-15mRA 15000±50mm

No	MATERIALS LIST:
1.	CABLE: 3 x (2 x 24 AWG)ST + 2 x 22 AWG O.D.:8.8mm COLOR:RED LILAC
2.	CONNECTOR:USB 3.0 A/M, 9P, BLUE INSULATOR SOLDER TYPE, NICKEL PLATED SHELL
3.	CONNECTOR:USB 3.0 MicroB/M, 10P, BLACK INSULATOR SOLDER TYPE, NICKEL PLATED SHELL
4.	PVC MOLDED HOUSING, BLACK COLOR
5.	SCREW:#4x23.32 M2
6.	DC JACK 1.3mm 30V 0.3V

PIN OUT

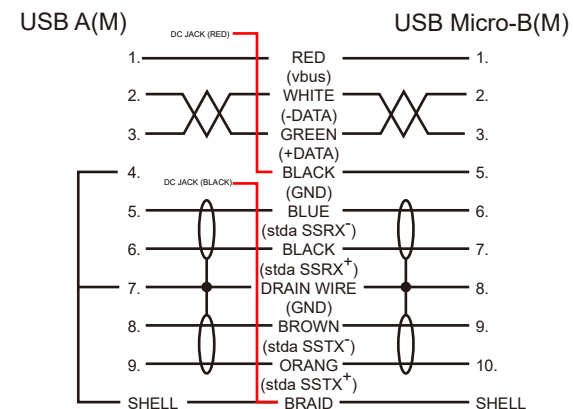

Jargy part no.	Client part no.	Approved	SCALE	UNIT
CBL-HFD3SAB6MBHPW-xmRA				mm
Drawing Name		Drawn	Date	REV.
USB 3.0 A to MicroB Cable M/M				1.0

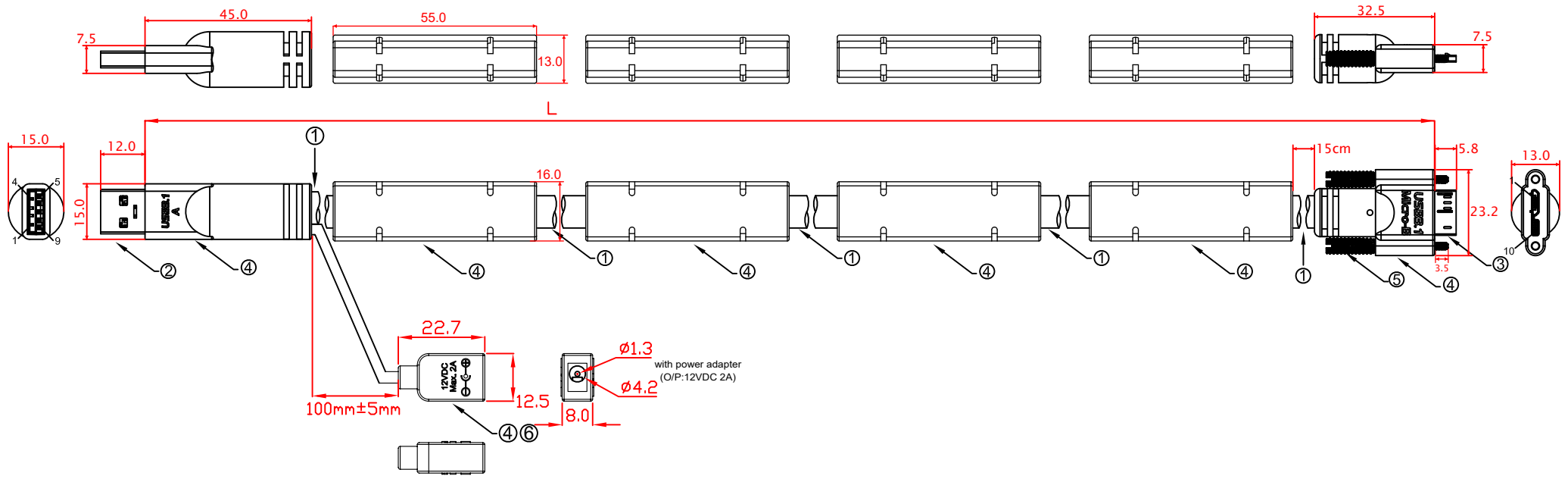

PIN OUT

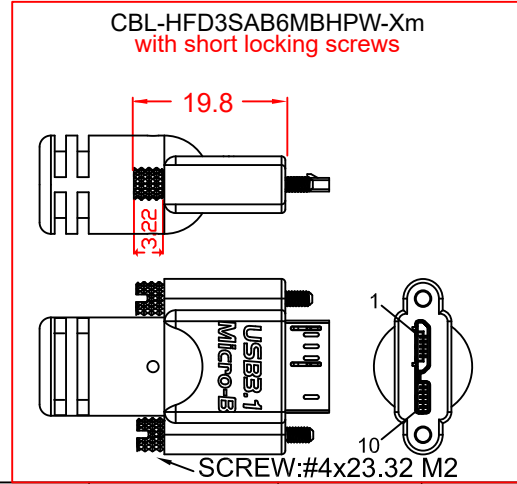
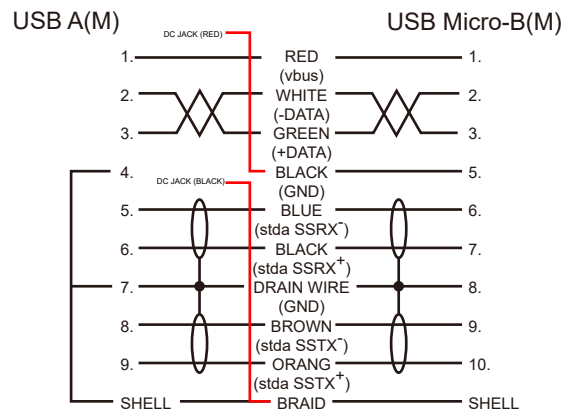

L:
CBL-HFD3SAB6MBSPW-20m 20000±50mm

No	MATERIALS LIST:
1.	CABLE: 3 x (2 x 24 AWG)ST + 2 x 22 AWG O.D.:8.8mm COLOR:RED LILAC
2.	CONNECTOR:USB 3.0 A/M, 9P, BLUE INSULATOR SOLDER TYPE, NICKEL PLATED SHELL
3.	CONNECTOR:USB 3.0 MicroB/M, 10P, BLACK INSULATOR SOLDER TYPE, NICKEL PLATED SHELL
4.	PVC MOLDED HOUSING, BLACK COLOR
5.	SCREW:#4x33 M2
6.	DC JACK 1.3mm 30V 0.3V

Jargy part no.	Client part no.	Approved	SCALE	UNIT
CBL-HFD3SAB6MBSPW-xm				mm
Drawing Name		Drawn	Date	REV.
USB 3.0 A to MicroB Cable M/M				1.0

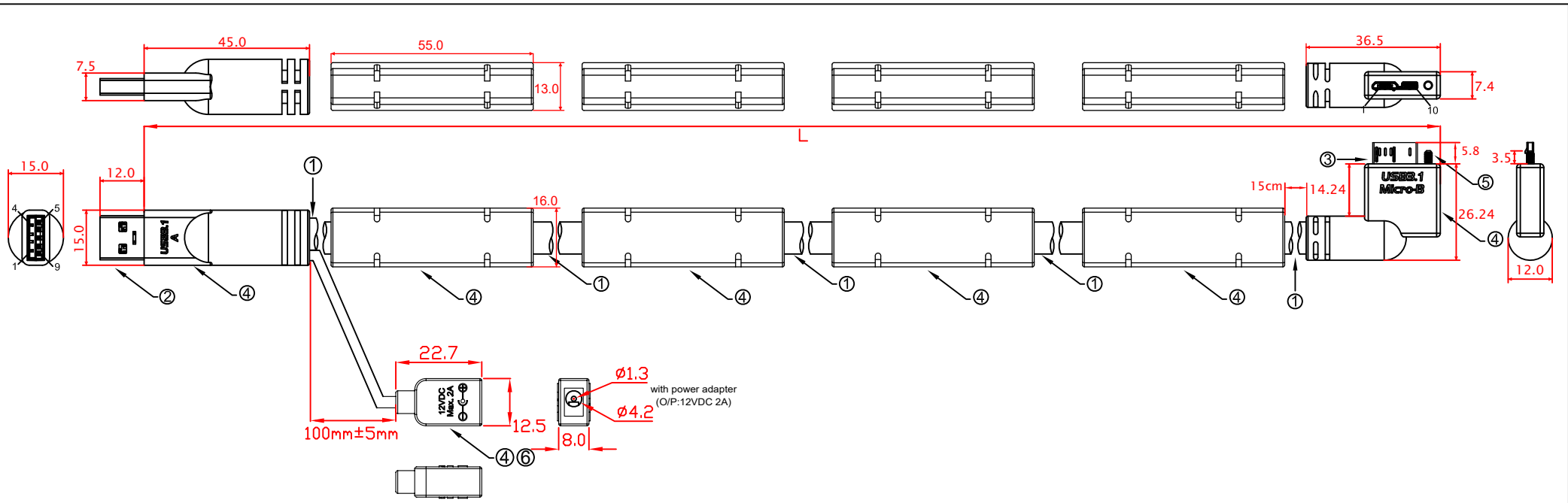

L:
CBL-HFD3SAB6MBHPW-20mLA 20000±50mm

No	MATERIALS LIST:
1.	CABLE: 3 x (2 x 24 AWG)ST + 2 x 22 AWG O.D.:8.8mm COLOR:RED LILAC
2.	CONNECTOR:USB 3.0 A/M, 9P, BLUE INSULATOR SOLDER TYPE, NICKEL PLATED SHELL
3.	CONNECTOR:USB 3.0 MicroB/M, 10P, BLACK INSULATOR SOLDER TYPE, NICKEL PLATED SHELL
4.	PVC MOLDED HOUSING, BLACK COLOR
5.	SCREW:#4x23.32 M2
6.	DC JACK 1.3mm 30V 0.3V

PIN OUT

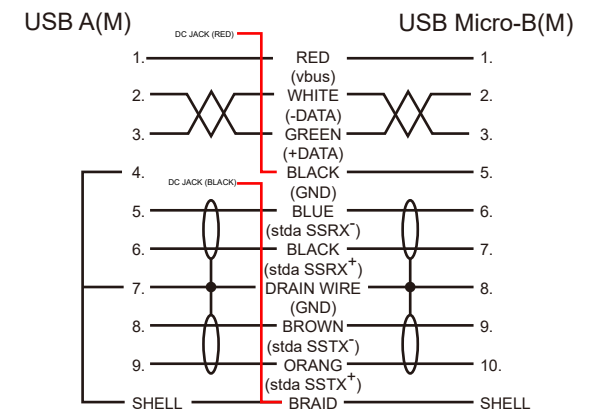

Jargy part no.	Client part no.	Approved	SCALE	UNIT
CBL-HFD3SAB6MBHPW-xmLA				mm
Drawing Name		Drawn	Date	REV.
USB 3.0 A to MicroB Cable M/M				1.0

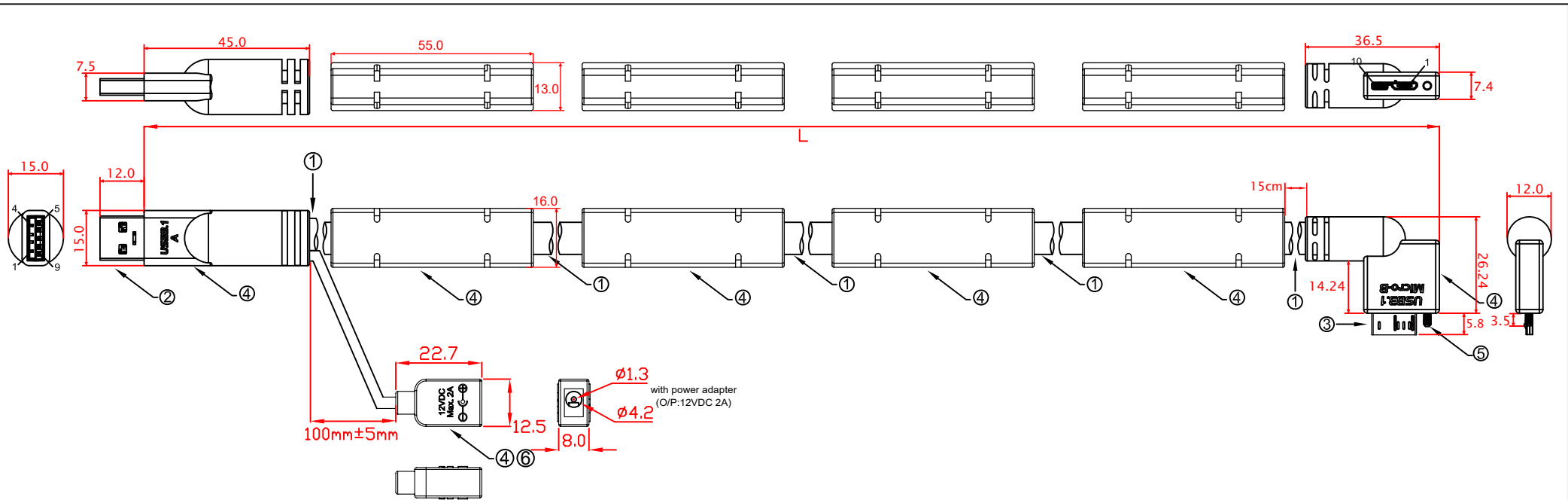

L:
CBL-HFD3SAB6MBHPW-20mRA 20000±50mm

No	MATERIALS LIST:
1.	CABLE: 3 x (2 x 24 AWG)ST + 2 x 22 AWG O.D.:8.8mm COLOR:RED LILAC
2.	CONNECTOR:USB 3.0 A/M, 9P, BLUE INSULATOR SOLDER TYPE, NICKEL PLATED SHELL
3.	CONNECTOR:USB 3.0 MicroB/M, 10P, BLACK INSULATOR SOLDER TYPE, NICKEL PLATED SHELL
4.	PVC MOLDED HOUSING, BLACK COLOR
5.	SCREW:#4x23.32 M2
6.	DC JACK 1.3mm 30V 0.3V

PIN OUT

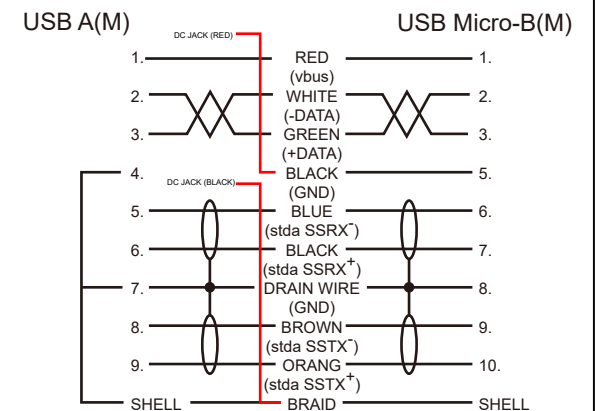

Jargy part no.	Client part no.	Approved	SCALE	UNIT
CBL-HFD3SAB6MBHPW-xmRA				mm
Drawing Name		Drawn	Date	REV.
USB 3.0 A to MicroB Cable M/M				1.0